

### KEY FEATURES

- Designed for compression drivers with 1" mouth diameter
- It provides uniform response, on and off-axis with a neutral and natural frequency reproduction
- Coverage angles of 90° in the horizontal plane and 40° in the vertical plane
- Straightforward mounting in compact enclosures thanks to its plane mouth finish and minimised horn depth



### GENERAL DESCRIPTION

This 1" throat entry horn is constructed of cast aluminium, and is designed to provide uniform on and off-axis frequency response, with uncoloured and natural sound reproduction. The constant directivity characteristics of this model ensure the ability to cover 90° wide horizontally and 40° wide vertically, at virtually any frequency within its operational range. Since the response remains essentially constant, equalisation is easily simplified. Its flat front finish facilitates flush mounting.

### TECHNICAL SPECIFICATIONS

<b>Throat diameter</b>	25 mm. 1 in.
<b>Horizontal beamwidth</b>	90° (+0° -40°) (-6dB, 1.25 - 16 kHz)
<b>Vertical beamwidth</b>	40° (+40° -1°) (-6dB, 2 - 16 kHz)
<b>Directivity factor (Q)</b>	11.8 (average 1.25 -16 kHz)
<b>Directivity index (DI)</b>	10.7 dB (+2.3 dB, -3.1 dB)
<b>Cutoff frequency</b>	1.2 kHz
<b>Dimensions</b>	W x H x D: 230 x 170 x 92 mm.
<b>Cutout dimensions</b>	W x H: 180 x 136 mm.
<b>Net weight</b>	0.9 kg.
<b>Shipping weight</b>	1 kg.
<b>Construction</b>	Cast aluminium.
Connection of driver by three screws on a 57 mm. diameter bolt circle.	

### DIMENSION DRAWINGS

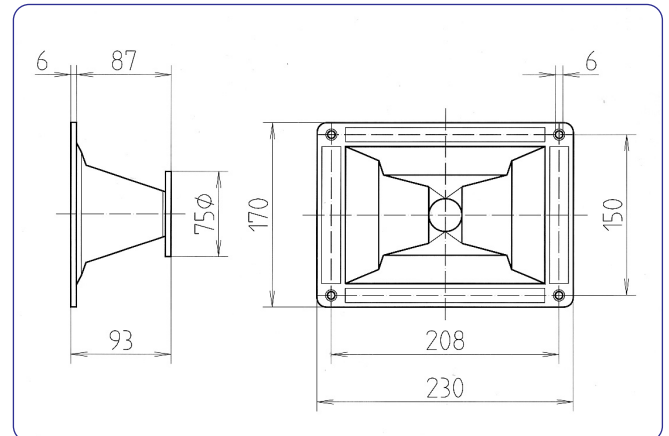

### -6dB BEAMWIDTH\*

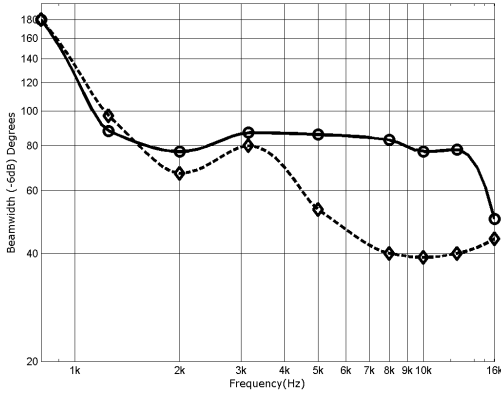

### DIRECTIVITY

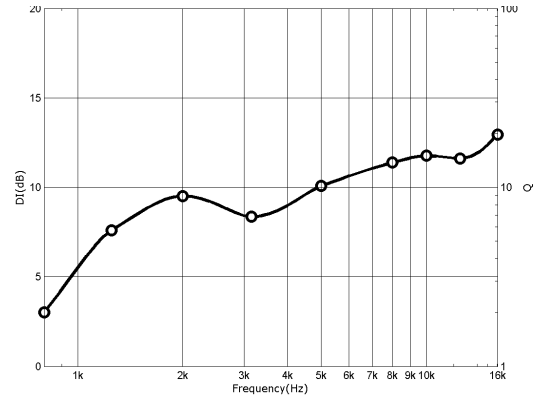

### POLAR RESPONSE\*\*

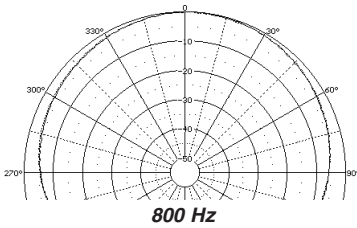

800 Hz

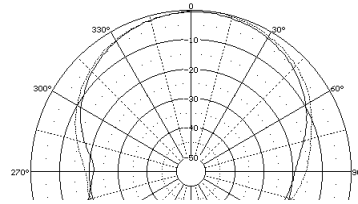

1,25 kHz

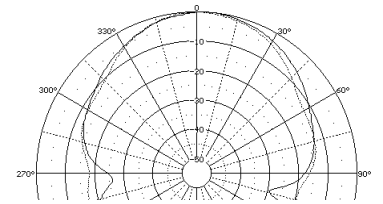

2 kHz

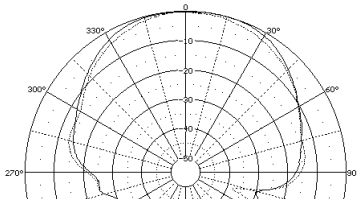

3,15 kHz

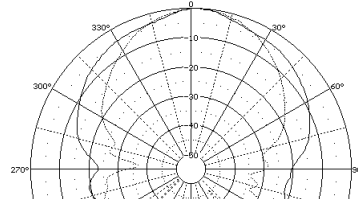

5 kHz

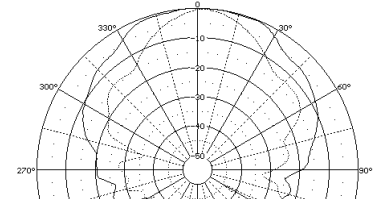

8 kHz

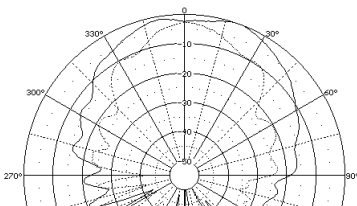

10 kHz

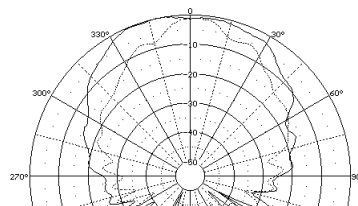

12,5 kHz

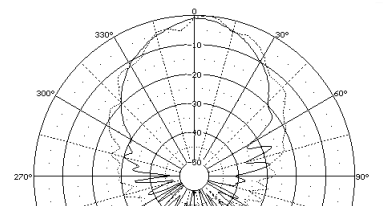

16 kHz

#### NOTES.

\* Horizontal beamwidth is represented by the heavy line. Vertical beamwidth is represented by the discontinuous line.

\*\* Horizontal response is represented by the heavy lines. Vertical response is represented by the discontinuous lines. The polar plots are reproduction of measurements done with single sinusoidal signal tones, at the indicated frequencies. The microphone was placed 2 m from the horn, and rotation was about the centre of the emitter source.



acústica beyma, s.a.